

CHAMPION
CUTTING TOOL CORP

BRUTE
PLATINUM

XLT TAPPER

Tap More Holes • Save More Time • Create Precise Threads



OPERATOR'S MANUAL

Please Remember to Register Your Tapper Online at www.championcuttingtool.com



Power Input	4A / 450W	
Voltage	115V, 60Hz	
No Load min	Forward	280
	Reverse	680
Tapping Capacity	Steel	14mm (9/16")
	Aluminum	16mm (5/8")
Dimensions	400mm x 80mm x 200mm	
Net Weight	2.7 Kg (6 lbs) (Not including side handle 0.45 Kg (1 lb))	

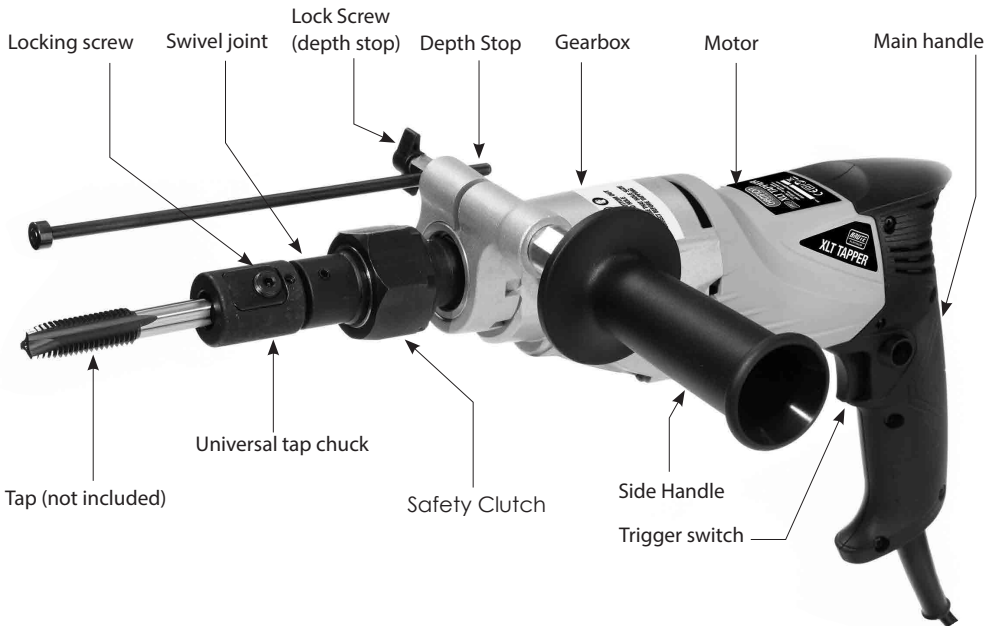

Warning: This power tool is equipped with over load protection. If tool overheats, switch off for at least 3 minutes to reduce temperature before switching on again.



GENERAL SAFETY INSTRUCTIONS



WARNING! Read all safety warnings and all instructions. Failure to follow the warnings and instructions may result in electric shock, fire and/or serious injury.

Save all warnings and instructions for future reference.

1) WORK AREA SAFETY

- a. **Keep work area clean and well lit.** Cluttered or dark areas invite accidents.
- b. **Do not operate power tools in explosive atmospheres, such as in the presence of flammable liquids, gases or dust.** Power tools create sparks which may ignite the dust or fumes.
- c. **Keep children and bystanders away while operating a power tool.** Distractions can cause you to lose control.

2) ELECTRICAL SAFETY

- a. **Power tool plugs must match the outlet. Never modify the plug in any way. Do not use any adapter plugs with earthed (grounded) power tools.**
Unmodified plugs and matching outlets will reduce risk of electric shock.
- b. **Avoid body contact with earthed or grounded surfaces such as pipes, radiators, ranges and refrigerators.** There is an increased risk of electric shock if your body is earthed or grounded.
- c. **Do not expose power tools to rain or wet conditions.** Water entering a power tool will increase the risk of electric shock.
- d. **Do not abuse the cord. Never use the cord for carrying, pulling or unplugging the power tool. Keep cord away from heat, oil, sharp edges or moving parts.** Damaged or entangled cords increase the risk of electric shock.
- e. **When operating a power tool outdoors, use an extension cord suitable for outdoor use.**
Use of a cord suitable for outdoor use reduces the risk of electric shock.

- f. **If operating a power tool in a damp location is unavoidable, use an earth leakage circuit breaker.** Use of an earth leakage circuit breaker reduces the risk of electric shock.

3) PERSONAL SAFETY

- a. **Stay alert, watch what you are doing and use common sense when operating a power tool. Do not use a power tool while you are tired or under the influence of drugs, alcohol or medication.** A moment of inattention while operating power tools may result in serious personal injury.
- b. **Use personal protective equipment. Always wear eye protection.** Protective equipment such as dust mask, non-skid safety shoes, hard hat, or hearing protection used for appropriate conditions will reduce personal injuries.
- c. **Prevent unintentional starting. Ensure the switch is in the off-position before connecting to power source and/or battery pack, picking up or carrying the tool.**
Carrying power tools with your finger on the switch or energising power tools that have the switch on invites accidents.
- d. **Remove any adjusting key or wrench before turning the power tool on.** A wrench or a key left attached to a rotating part of the power tool may result in personal injury.
- e. **Do not overreach. Keep proper footing and balance at all times.** This enables better control of the power tool in unexpected situations.
- f. **Dress properly. Do not wear loose clothing or jewelry. Keep your hair, clothing and gloves away from moving parts.** Loose clothes, jewelry or long hair can be caught in moving parts.
- g. **If devices are provided for the connection of dust extraction and collection facilities, ensure these are connected and properly used.** Use of dust collection can reduce dust-related hazards.

4) POWER TOOL USE AND CARE

- a. **Do not force the power tool. Use the correct power tool for your application.** The correct power tool will do the job better and safer at the rate for which it was designed.
- b. **Do not use the power tool if the switch does not turn it on and off.** Any power tool that cannot be controlled with the switch is dangerous and must be repaired.
- c. **Disconnect the plug from the power source before making any adjustments, changing accessories, or storing power tools.** Such preventive safety measures reduce the risk of starting the power tool accidentally.
- d. **Store idle power tools out of the reach of children and do not allow persons unfamiliar with the power tool or these instructions to operate the power tool.** Power tools are dangerous in the hands of untrained users.
- e. **Maintain power tools. Check for misalignment or binding of moving parts, breakage of parts and any other condition that may affect the power tool's operation. If damaged, have the power tool repaired before use.** Many accidents are caused by poorly maintained power tools.
- f. **Keep cutting tools sharp and clean.** Properly maintained cutting tools with sharp cutting edges are less likely to bind and are easier to control.
- g. **Use the power tool and accessories in accordance with these instructions, taking into account the working conditions and the work to be performed.** Use of the power tool for operations different from those intended could result in a hazardous situation.

5) SERVICE

Have your power tool serviced by a qualified repair person using only identical replacement parts. This will ensure that the safety of the power tool is maintained.

Symbols used in this manual

- V.....volts
- A.....amperes
- Hz.....hertz
- W.....watt
- ~.....alternating current
- n_0no load speed
- min^{-1}revolutions or reciprocation per minute



.....warning of general danger



.....class II tool



.....with electrical earth



.....read these instructions



.....always wear eye protection



.....always wear a dust mask.



.....always wear hearing protection



.....wear safety-approved hard hat



.....Keep hands clear – pinching hazard.



DANGER! Keep hands away from cutting area and the blade.



rotating parts - entanglement hazard. Keep hands, loose clothing and long hair away from moving parts



do not dispose of electric tools, accessories and packaging together with household waste material



Terminology used in the manual

1. Warning: This term means that there is a risk of physical harm or death to the operator or people nearby.

2. Caution: This term means that there is a risk of damage to the machine, cutting tool or other equipment

3. Note: This term offers useful information relating to the operation of the machine or its maintenance.

SPECIFIC SAFETY INSTRUCTIONS

- 1. Do not operate with dull or damaged cutting tools.** This may overload the motor.
- 2. Protect the motor.** Never allow coolant fluid, water, or other contaminants to enter the motor.
- 3. Metal chips are often very sharp and hot.** Never touch them with bare hands. Clean up with a magnetic chip collector or other appropriate tool.

WARNING: NEVER attempt to use machine with incorrect current or abnormally low voltage. Check machine nameplate to ensure that correct voltage and Hz are used.

INTRODUCTION

This machine is specifically designed for tapping of pre-drilled, correct sized through holes or blind holes in various metals. Its gearbox is specially designed to spin clockwise when downforce is

applied, to not spin when no downforce is applied, and to spin counterclockwise when upforce is applied. This makes it fast and convenient to tap and then to remove the tap. This machine is only for tapping. All other uses are prohibited.

LIST OF CONTENTS

- Brute Platinum XLT Tapper
- Side Handle
- Depth Stop
- 4mm Hex Key
- Carrying Case

ASSEMBLY

Mount the side handle to the front of the gearcase and turn the grip clockwise to tighten.

CAUTION: Before tapping ensure that the hole is the correct size for the tap. An undersize hole will cause the tap to jam causing a hazardous situation.

CAUTION: When tapping a blind hole do not bottom-out the tap. Bottoming will cause the tap to jam, causing a hazardous situation.

PROPER LUBRICATION:

Always apply cutting fluid for smooth tapping.

SETTING UP FOR TAPPING

CAUTION: Never use a cutting tool which is larger than the maximum rated capacity of the machine.

CAUTION: Always select the recommended size tap.

Note: Always use cutting fluid to provide smooth threading and prolong tap life.

Using the universal tap chuck, use the key to turn it to open its jaws enough to fit the square of the tap. Ensure that the corners of the square are properly located in the jaws. Then use the key to securely tighten the chuck.

NOTE: Make sure that the tap is inserted as deeply as possible into the jaws. An improperly seated tap will run off center and could result in damage to the jaws or tap.

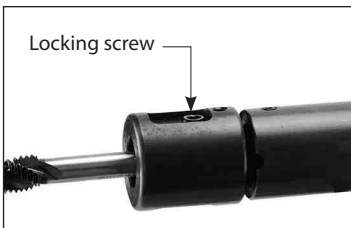
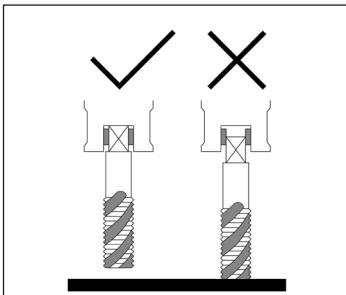

ALWAYS ENSURE THAT THE HOLE ISN'T OVER TAPPED. THE HOLE'S DEPTH MUST BE LONGER THAN THE NEEDED THREADING DEPTH!! ALWAYS HOLD THE TOOL AS STRAIGHT AS POSSIBLE TO AVOID BREAKING THE TAP OR CREATING TOO MUCH TORQUE

THE SWITCH

To Switch On:

Squeeze the trigger switch and hold to turn the motor on.

To switch off:

Release the trigger switch.

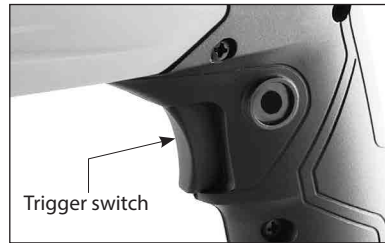

TAPPING OPERATION

NOTE: It is recommended to always use cutting oil on the tap to give longer tap life and better results.

1. Prior to tapping, make sure the hole size is correct.
2. Install tap into the Brute XLT and insert the point of the tap into the pre-drilled hole.
3. Squeeze the trigger when there is no feed pressure on the tap. Apply downward pressure and the spindle will automatically spin in right hand (clockwise) direction at low speed. Hold the machine as square as possible with the

hole. (The swivel joint will take up small amounts of misalignment)

4. Once the hole is tapped, release the downward feed pressure and the spindle will stop.
5. When the machine is pulled back, the spindle will automatically spin in the left hand (counterclockwise) direction at high speed (in order to more quickly remove the tap).

CAUTION: Do not pull too hard when backing out or the tap could pull out of the chuck. This could lead to premature wear of the chuck.

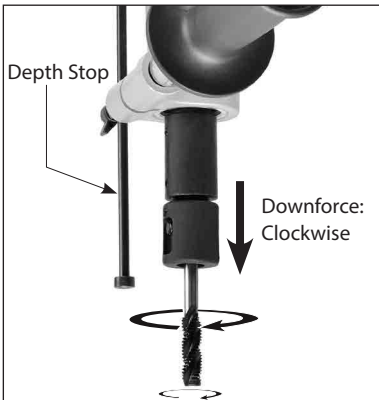

THE DEPTH STOP

The depth stop is useful when tapping blind holes to avoid bottoming out the tap. It may be moved back out of the way (or removed entirely) when not needed.

To set the depth stop:

1. Loosen the locking screw and adjust the bar so that it is flush with the end of the tap. This will be the zero position.
2. Take the intended tapping depth and subtract 4mm. Then back off the bar by this amount. (4mm must be subtracted because of the internal mechanism)
3. Once the desired position is set, retighten the lock screw.

Example: If the desired tapping depth is 14mm, then the depth stop bar should be set to 10mm back from the end of the tap. (14mm minus 4mm = 10mm)

NOTE: It is not possible to tap left-hand threads with this machine

WARNING: Always hold tightly to both handles to resist the torque forces created during the tapping operation.

WARNING: Never attempt to tap without using the side handle and always ensure that the handle is tight before operating.

MAINTENANCE

Every 50 hours of operation blow compressed air through the motor while running at no load to clean out accumulated dust. (If operating in especially dusty conditions, perform this operation more often.)

Keep the machine clean and free of chips.

Check for loose fittings and tighten as needed.

Ensure that the ventilation slots are clear so that motor can be cooled normally. Blow low pressure compressed air through the ventilation slots with the motor running to keep motor clean.

THE CARBON BRUSHES

The carbon brushes are a normal wearing part and must be replaced when they reach their wear limit.

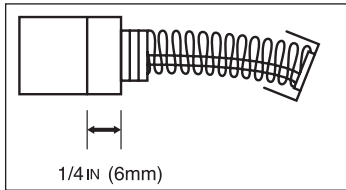

with the holder.

5. Install the new brush into the brush holder with the male spade end pointing toward the rear of the motor then screw the brush holder in place.
6. Reconnect the female spade terminal to the brush. Then repeat for the other brush.
7. Replace the right handle housing, then carefully place the switch in the correct position and arrange the wires so that they will not be pinched.
8. Replace the left handle housing, taking care to avoid pinching any wires and tighten the screws.

Always entrust all repairs to an authorized service agent.

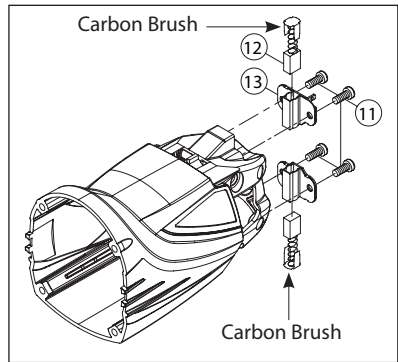

TO REPLACE BRUSHES

1. Remove the 5 long screws and 2 short screws to remove the left handle housing. (The two screws closest to the motor are the short screws).
2. Remove the 2 short screws to remove the right handle housing. There will be wires which will remain attached. Take care not to strain the wires.
3. Unplug the female spade terminal from the brush.
4. Unscrew the 2 screws to remove the brush holder. The brush will come away together

If the replacement of the power supply cord is necessary, this has to be done by the manufacturer or their agent in order to avoid a safety hazard.

WARNING: All repairs must be entrusted to an authorized service center. Incorrectly performed repairs could lead to injury or death.

WIRING

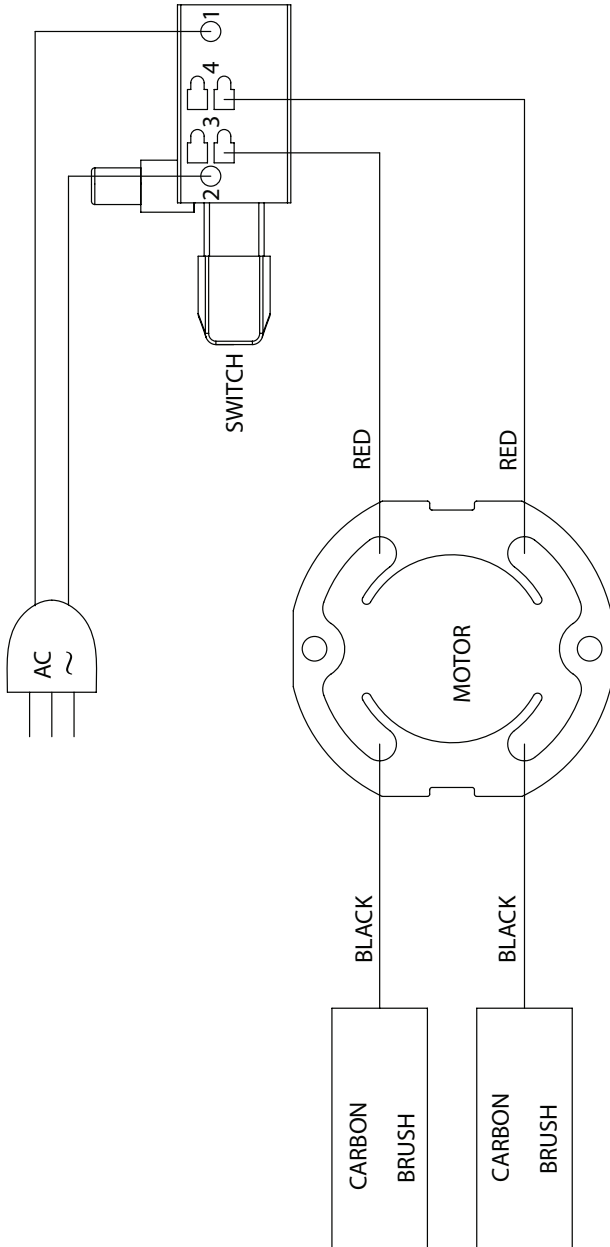

EXPLODED VIEW

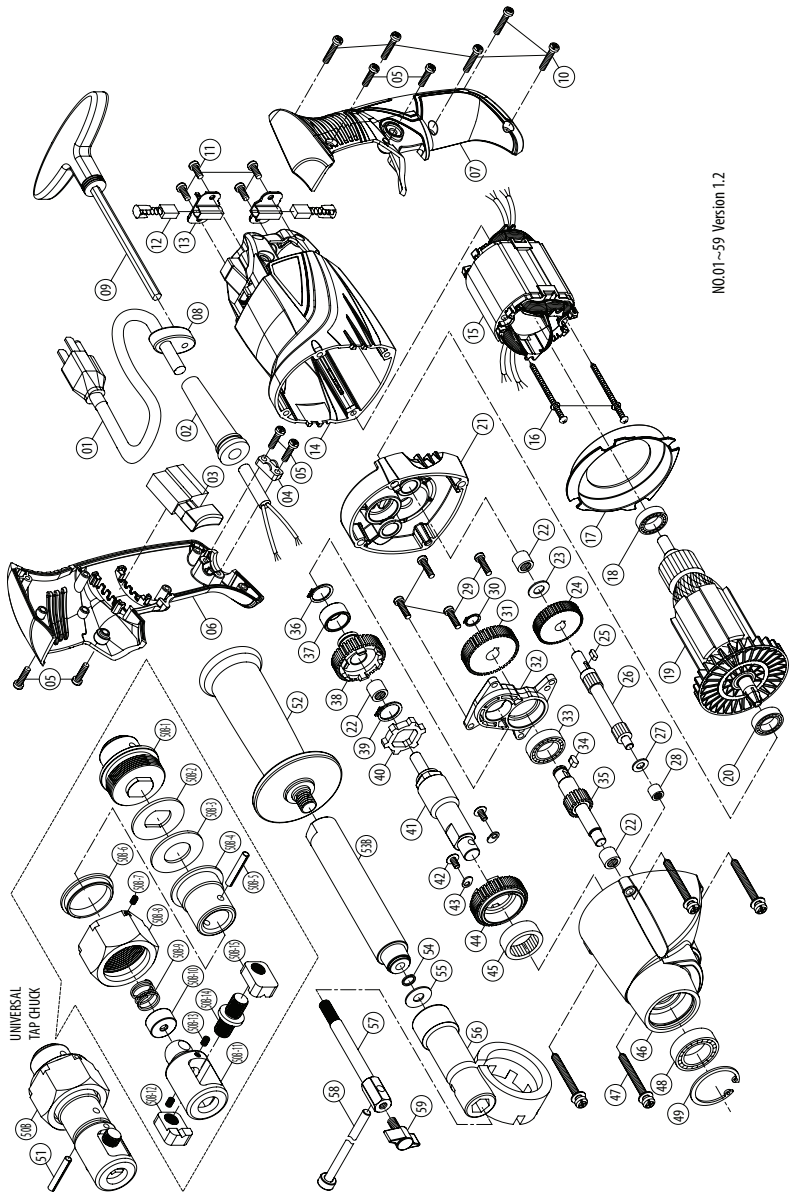

NO.01-59 Version 1.2

UNIVERSAL
TAP CHUCK

PARTS LIST

Part No.	Description	QTY	Part No.	Description	QTY
XLT-1	POWER SUPPLY CABLE 16AX2CX3M SJTW	1	XLT-38	OUTPUT GEAR M1.0 x 38T	1
XLT-2	CORD ARMOR	1	XLT-39	EXTERNAL CIRCLIP S-17	1
XLT-3	TRIGGER SWITCH	1	XLT-40	TAP SPINDLE ENGAGEMENT GEAR	1
XLT-4	CABLE CLIP	1	XLT-41	SPINDLE	1
XLT-5	PANHEAD TAPPING SCREW M4 x 14	6	XLT-42	TRUSS HEAD MACHINE SCREW M4 x 8	2
XLT-6	HANDLE HALF-RIGHT	1	XLT-43	TAB	2
XLT-7	HANDLE HALF-LEFT	1	XLT-44	REVERSING DRIVE GEAR M0.9 x 44T	1
XLT-8	HEX KEY HOLDER	1	XLT-45	NEEDLE BEARING TA 2210	1
XLT-9	CHUCK KEY M4	1	XLT-46	GEARCASE	1
XLT-10	PANHEAD TAPPING SCREW M4 x 16	5	XLT-47	PANHEAD TAPPING SCREW M5 x 45	4
XLT-11	PANHEAD TAPPING SCREW M4 x 8	4	XLT-48	BALL BEARING 6003-2NSE	1
XLT-12	CARBON BRUSH 7 x 8 x 12	2	XLT-49	INTERNAL CIRCLIP R-35	1
XLT-13	CARBON BRUSH HOLDER	2	XLT-50B	UNIVERSAL TAP CHUCK W / CLUTCH	1
XLT-14	MOTOR HOUSING	1	XLT-50B-1	HUB	1
XLT-15	STATOR	1	XLT-50B-2	DISC SPRING Ø20.4 x Ø40 x 2.25	1
XLT-16	PANHEAD TAPPING SCREW M4 x 60	2	XLT-50B-3	FRICTION DISC Ø20.4 x Ø40 x 2	1
XLT-17	FAN SHROUD	1	XLT-50B-4	SWIVEL BARREL	1
XLT-18	BALL BEARING 608 ZZ	1	XLT-50B-5	ROLL PIN Ø5 x 30	1
XLT-19	ARMATURE M0.7 x 7T	1	XLT-50B-6	FRICTION COLLAR	1
XLT-20	BALL BEARING 609-2RS	1	XLT-50B-7	SOCKET SET SCREW M4 x 6	1
XLT-21	GEAR PLATE	1	XLT-50B-8	HEX NUT	1
XLT-22	NEEDLE BEARING HK 0810	3	XLT-50B-9	SPRING Ø1.7 x Ø13 x Ø16.4 x 18.5L x 4T	1
XLT-23	THRUST RING 816	1	XLT-50B-10	HEAD LOCKING KNOB	1
XLT-24	INPUT GEAR M0.7 x 46T	1	XLT-50B-11	CHUCK BODY	1
XLT-25	PARALLEL KEY 3 x 3 x 8	1	XLT-50B-12	JAW-RIGHT HAND THREAD M12 x P1.25	1
XLT-26	INPUT SHAFT M0.9 x 10T	1	XLT-50B-13	SOCKET SET SCREW M5 x 12	2
XLT-27	FLAT WASHER Ø6 x Ø13 x 1	1	XLT-50B-14	FENCE LOCK STUD M12 x P1.25	1
XLT-28	NEEDLE BEARING HK0608	1	XLT-50B-15	JAW-RIGHT HAND THREAD M12 x P1.25	1
XLT-29	SOCKET CAP SCREW M4 x 14	4	XLT-52	FRONT HANDLE (M12xP1.75) M12	1
XLT-30	EXTERNAL CIRCLIP S-10	1	XLT-53B	SIDE HANDLE SHAFT	1
XLT-31	LAY GEAR M0.9 x 44T	1	XLT-54	SPRING WASHER M10	1
XLT-32	INNER GEAR PLATE	1	XLT-55	FLAT WASHER Ø10 x Ø18 x 2	1
XLT-33	BALL BEARING 6001 zz	1	XLT-56	SIDE HANDLE CLAMP	1
XLT-34	PARALLEL KEY 4 x 4 x 8	1	XLT-57	DEPTH LOCK SHAFT M8	1
XLT-35	COUNTERSHAFT M1.0 x 14T	1	XLT-58	DEPTH STOP	1
XLT-36	EXTERNAL CIRCLIP S-16	1	XLT-59	THUMB SCREW M6 x L12	1
XLT-37	BUSHING Ø16 x Ø20 x 10	1			

BRUTE
PLATINUM

XLT TAPPER



CHAMPION
CUTTING TOOL CORP

P.O. Box 368, Rockville Centre NY 11571-0368

Tel: 516-536-8200 Fax: 516-536-8186

championcuttingtool.com

© 2016 All Rights Reserved