



RB65E

MEGABRUTE
MAGNETIC DRILL PRESS

SAFETY & USAGE GUIDELINES · PARTS & SCHEMATICS





RB65E

MEGABRUTE

COMPONENTS & SAFETY

IMPORTANT

Please read these operating and safety instructions carefully and completely. For your own safety, before using this equipment check that the voltage is correct and that all handles and parts are firmly secured. If you are uncertain about any aspect of using this equipment, contact your distributor.

PLEASE KEEP THESE INSTRUCTIONS

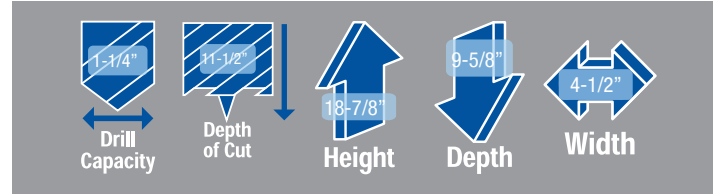
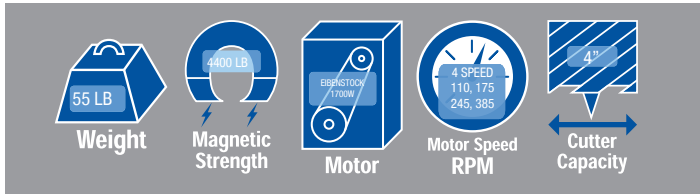

INCLUDED WITH EVERY RB65E

Carrying case, safety strap, RB65E634 3/4" arbor, cutting fluid, safety guard, drift key & hex keys

Ear and eye protection **MUST** be worn during operation of this equipment. Do **NOT** touch the cutter while it is in motion. Always follow the Personal Protection Equipment (PPE) recommendations while operating this tool.

This machine is designed specifically for drilling holes in steel using annular cutters or with twist drills when using the optional drill chuck. We recommend Champion® Rotobrutite™ annular cutters. Please consult your Champion authorized distributor for a complete range of sizes.

DO **NOT** modify and / or use your Rotobrutite™ Magnetic Drill Press for any application other than, for which it is intended.

SAFETY

Be sure to read and follow these important safety instructions:

When using your RB65E MegaBrute, be sure to follow these important safety precautions:

1. Before operating the machine, check supply voltage and general conditions, i.e. cable/cord damage. A machine with damaged cable must be returned or repaired prior to use.
2. Always use the safety strap in all drilling applications.
3. Since cutting tools can shatter, eye and head protection should be worn at all times.
4. After use, clean machine and cutters and keep in the case provided.
5. Store when not in use in a dry environment.
6. Always provide a method of catching slug, where the ejected slug may cause injury (slug ejects at end of cut).
7. Should the cutter jam in the work-piece, stop the machine immediately. Isolate the machine at the main supply. Loosen the cutter by rotating the arbor. Do not attempt to free cutter by starting and stopping the motor.
8. Always use the safety guard provided.

Electrical Safety

Grounded tools must be plugged into an outlet properly installed and grounded in accordance with all codes and ordinances. Never remove the grounding prong or modify the plug in any way.

Do not use any adapter plugs. Check with a qualified electrician if you are in doubt as to whether the outlet is properly grounded. If the tools should electrically malfunction or breakdown, grounding provides a low resistance path to carry electricity away from the user. Never use the cord to carry the tools or pull the plug from an outlet. Replace damaged cords immediately.

When operating a power tool outside, use an outdoor extension cord marked "W-A" or "W". These cords are rated for outdoor use and reduce the risk of electric shock. Minimum gauge external cord should be 12/3.

Do not use on any surface where welding is taking place.

Use the RB65E with 110 A/C voltage only.

Not for use with generators, welders or any DC power source.

Personal Safety

Stay alert, watch what you are doing and use common sense when operating a power tool. Do not use tool while tired or under the influence of drugs, alcohol, or medication.

Do not wear loose clothing or jewelry. Avoid accidental starting. Be sure switch is off before plugging in. Carrying tools with your finger on the switch or plugging in tools that have the switch on invites accidents.

Remove adjusting keys before turning the tool on.

Do not over reach. Keep proper footing and balance at all times.

Safety equipment (eye protection, dust mask, non-skid safety shoes, hard hat, hearing protection) should be used for appropriate conditions.

Tool Use and Care

Use clamps or other practical ways to secure and support the work-piece to a stable platform.

Do not force tool. Use the correct tool for the application.

Disconnect the plug from the power source before making any adjustments, changing accessories, or storing the tool.

Store idle tools out of reach of children and other untrained persons.

Maintain tools with care. Keep cutting tools sharp and clean.

Check for misalignment or binding of moving parts, breakage of parts and any other condition that may affect the tool's operation. If damaged, have the tool serviced before using.

Service

Tool service must be performed only by qualified and authorized personnel, or warranty is voided.

When servicing a tool, use only original replacement parts.

Use of unauthorized parts will void the warranty.

Use of unauthorized parts or failure to follow maintenance instructions may create a risk of electric shock or injury.

Magnetic Drill Safety

The drill's magnetic adhesion depends on the thickness of the work-piece. 1/2" (13mm) is the minimum thickness for safe operation. Keep the magnet clean of metal chips and other dirt and debris. These will seriously reduce the magnetic adhesion. The drill must be operated on its own electrical outlet. Always use the supplied safety strap or chain. An electrical overload can result in loss of adhesion.

CAUTION: The slug ejects at end of cut and is very hot.

WARNING: Do not attempt to drill a work-piece, which is thicker than the maximum cutting depth of the cutter being used. Never exceed 4" cutter diameter.

Maintenance and Troubleshooting

Keep the drill press and the cord clean. In case of electrical or mechanical malfunction, immediately switch off the tool and disconnect the plug. Excessive sparking generally indicates the presence of dirt in the motor or worn out carbon brushes.

Periodically check brushes for wear and replace when they reach 1/4" (6mm).

Also check that the machine is well lubricated.

For all other service and maintenance, please contact a Champion® authorized service center.

www.championcuttingtool.com

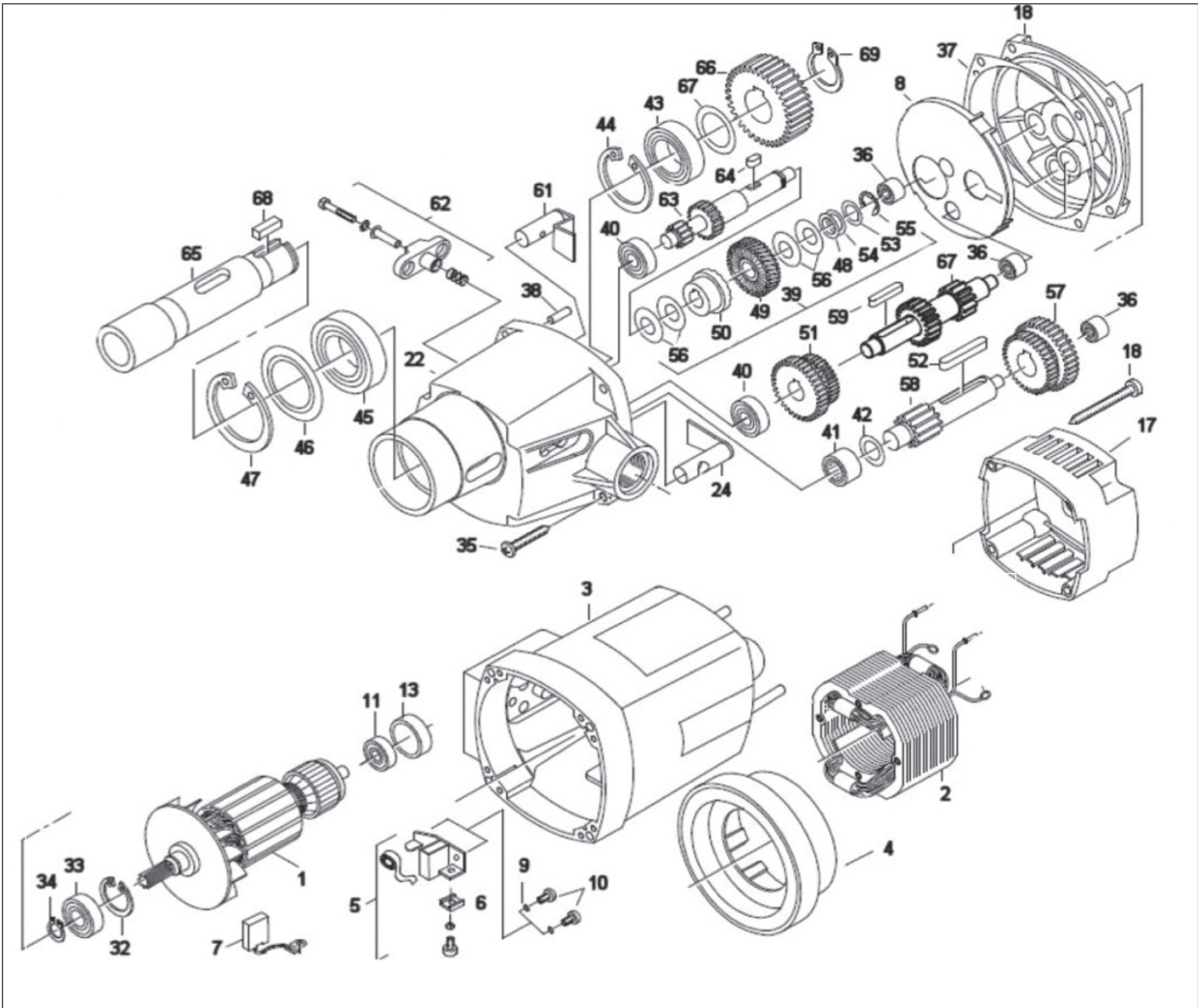

No. List/Size Description (Qty per machine)			No. List/Size Description (Qty per machine)			No. List/Size Description (Qty per machine)		
1	RB65E-E01	Armature (1)	34	RB65E-E34	Circlip (1)	52	RB65E-E52	Key 6 x 6 x 40 (1)
2	RB65E-E02	Stator (1)	35	RB65E-E35	Self tapping screw (4)	53	RB65E-E53	Lock washer (1)
3	RB65E-E03	Motor Housing (1)	36	RB65E-E36	Needle sleeve (3)	54	RB65E-E54	Thrush washer (1)
4	RB65E-E04	Air conductive ring (1)	37	RB65E-E37	Gearbox sleeve (1)	55	RB65E-E55	Circlip (1)
5	RB65E-E05	Brush holder complete (2)	38	RB65E-E38	Pin (1)	56	RB65E-E56	Disc spring (2)
6	RB65E-E06	Contact washer (2)	39	RB65E-E39	Clutch assembly (1)	57	RB65E-E57	Gear Cluster (1)
7	RB65E-E07	Carbon brush set of 2 (1)	40	RB65E-E40	Grooved bearing (2)	58	RB65E-E58	Internal shaft (1)
8	RB65E-E08	Grease barrier (1)	41	RB65E-E41	Needle bearing (1)	59	RB65E-E59	Key 6 x 6 x 40 (1)
9	RB65E-E09	Spring washer (4)	42	RB65E-E42	Washer (1)	61	RB65E-E61	Gear Selector (1)
10	RB65E-E10	M4 screw (4)	43	RB65E-E43	Grooved bearing (1)	62	RB65E-E62	Gear selector complete (1)
11	RB65E-E11	Grooved bearing (1)	44	RB65E-E44	Circlip (1)	63	RB65E-E63	Internal shaft (1)
13	RB65E-E13	Bearing cap (1)	45	RB65E-E45	Grooved bearing (1)	64	RB65E-E64	Key 5 x 5 x 10 (1)
17	RB65E-E17	Motor housing cap (1)	46	RB65E-E46	Washer (1)	65	RB65E-E65	Spindle (1)
18	RB65E-E18	Self tapping screw (4)	47	RB65E-E47	Circlip (1)	66	RB65E-E66	Spindle gear (1)
22	RB65E-E22	Gearbox housing (1)	48	RB65E-E48	Thrust washer (1)	67	RB65E-E67	Internal shaft (1)
24	RB65E-E24	Gear selector (1)	49	RB65E-E49	Coupling wheel (1)	68	RB65E-E68	Key 6 x 6 x 20 (1)
32	RB65E-E32	Circlip (1)	50	RB65E-E50	Gear coupling half (1)	69	RB65E-E69	Circlip (1)
33	RB65E-E33	Grooved bearing (1)	51	RB65E-E51	Gear cluster (1)			



RB65E MEGABRUTE

STAND SCHEMATIC

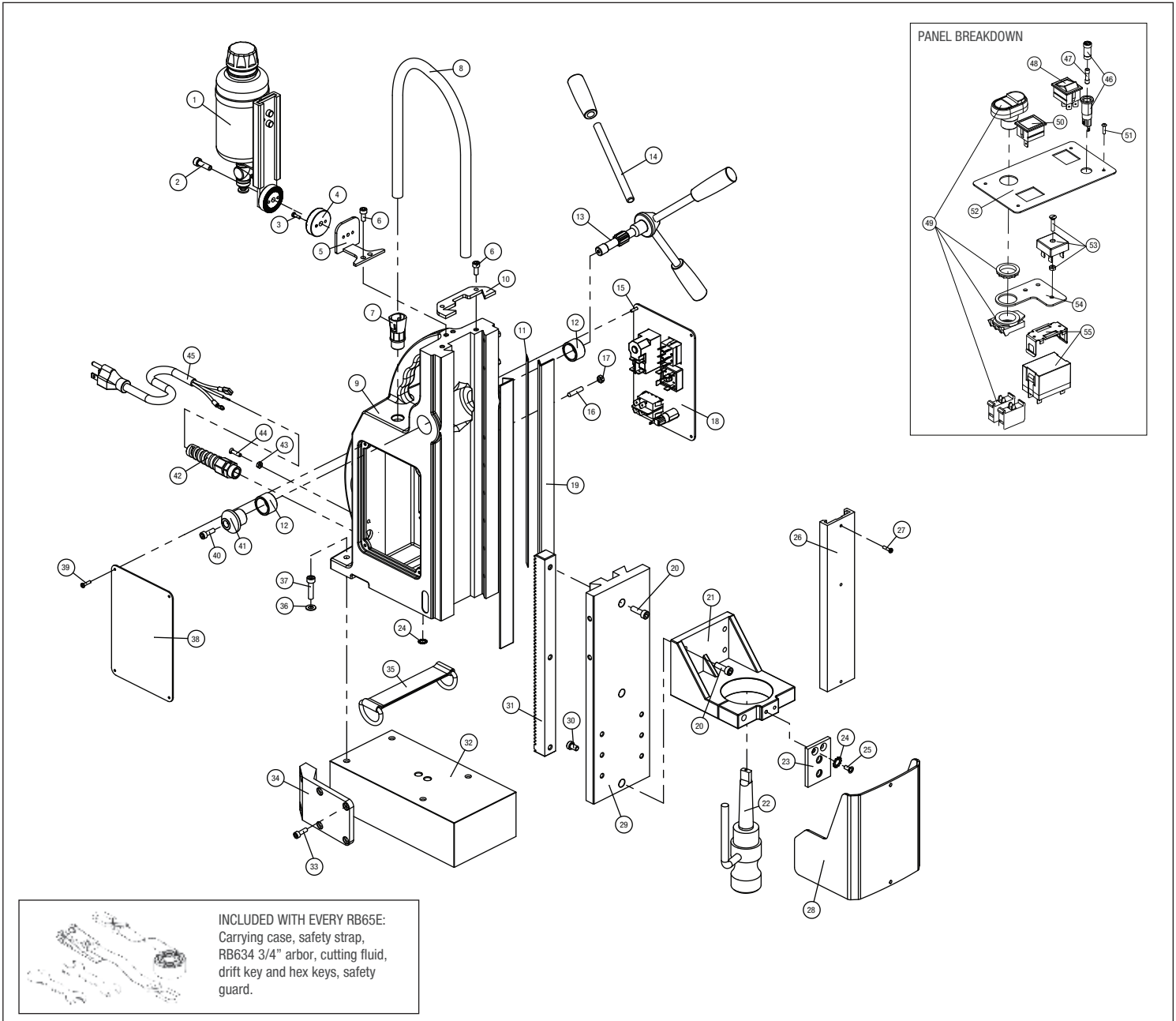

No. List/Size Description (Qty per machine)

1	RB3202	Coolant Bottle Assembly (1)
2	RB3201	M6 x 25 Cap Head Screw (1)
3	RB3203	M4 x 10 Cap Head Screw (2)
4	RB3204	Fixed Ratchet Wheel (1)
5	RB3205	Coolant Bracket (1)
6	RB3206	M5 x 12 Cap Head Screw (4)
7	RB519A	Gland AL16/M16/A (1)
8	RB506	Conduit Assembly (1)
9	RB601	Main Body Casting (1)
10	RB65E10	Laser Profile (1)
11	RB65E11	Shim Strip 379mm x 11mm x 0.7mm (1)
12	RB502	20 x 20 x 15 Bush (2)
13	RB614	PB100 Pinion (1)
14	RB718	Large Handle & Knob Assembly (3)
15	RB3215	M3 X 10 Panel Screw (4)
16	RB65E16	M5 X 25 Grub Screw (8)
17	RB3214	M5 Steel Nut (8)
18	RB65E-637	PB100E Panel (1)
19	RB613	Brass Guide (2)
20	RB65E22	M6 x 20 Cap Head Screw (3)

No. List/Size Description (Qty per machine)

21	RB65E-6051	Lower Support Bracket (1)
22	RB65E634	No.3 MT Arbor Assembly (1)
23	RB65E24	Guard Support (1)
24	RB65E25	M6 Schnorr Washer (2)
25	RB65E26	M5 x 15 C/SNK Head Screw (2)
26	RB65E27	Guard Slide Channel (1)
27	RB65E28	M4 x14 Button Head Screw (2)
28	RB65E29	Guard (1)
29	RB604	Dovetail Slide (1)
30	RB65E31	M6 x 10 Cap Head Screw (1)
31	RB625	Large Rack (1)
32	RB602	Magnetic Base Assembly (1)
33	RB65E34	NO.12 x 1 Pozzi Pan Head Screw (4)
34	RB65E-6231	Side Bracket (1)
35	RB65E36	D Ring Strap (1)
36	RB65E37	M6 Steel Washer (4)
37	RB65E38	M6 x 25 Cap Head Screw (6)
38	RB617	Rear Plate (1)
39	RB3215	M3 x 10 Panel Screws (4)
40	RB221	M5 x 15 Cap Head Screw (1)

No. List/Size Description (Qty per machine)

41	RB524	Pinion End Cap (1)
42	RB519	Cable Gland (1)
43	RB65E44	M16 Cable Gland Spiral Tail (1)
44	RB65E45	M4 INT. S/Proof Washer
45	RB503	Mains Cable
46	RB511	Fuse Holder (1)
47	RB512	2A Fuse (1)
48	RB505	Mag Switch 110V (1)
49	RB509	Stop/Start Switch (1)
50	RB65E-624	Neon Indicator Light (1)
51	RB65E6	M4 Screw (4)
52	RB616	Switch Panel (1)
53	RB515	Rectifier Unit (1)
54	RB65E9	L Shape Connecting Bracket
55	RB513	Power Relay 110V (1)



RB65E MEGABRUTE

OPERATING INSTRUCTIONS

Operating Instructions

1. Place a pilot pin in the cutter at the shank end. Insert the cutter into the special arbor, aligning the flats to the set screws on the arbor. Secure the set screws to the cutter with the supplied hex wrench.
2. Position the machine on a clean, dry, ferrous surface at least 1/2" thick. Switch on the magnet.
3. Cutting fluid must be used at all times to enhance the quality of cut and prolong the cutting tool life. Cutting fluid is applied through small holes located at the top/shank end of the arbor and feeds via gravity.
4. Switch on the drill. Always proceed with caution at the start of drilling operations. When using RotoBrute annular cutters apply pressure gradually at first until a depth of 1/8" is reached. Normal cutting pressure can then be applied.
5. On completion of cut, withdraw the cutter from hole, switch off the drill, then the magnet. Ensure the magnet base is clear of chips. Locate the next hole using the above procedures.

Adjusting Dovetail Slides

Slowly adjust the hex screws while moving the handle up and down. Adjust so there is no free play or no binding anywhere through its range of travel. Periodically check, lubricate, and adjust as necessary.

Repositioning of Handles

1. Elevate the slide upward to its full extent.
2. Remove the pinion cap screw and pinion cap from the shaft end (opposite side to handles).
3. Slide the pinion with the handles on outward, approximately 1/3 distance.
4. Disengage the rack by means of raising the slide up by another 3/4".
5. Remove pinion, reposition through opposite side of body casting and reverse procedure as above.

Assembly of Traverse Handles

1. To assemble traverse handle, place each of the three (3) handles into the threaded holes on the pinion rack, turning clockwise to tighten.
2. To remove handles, turn counter-clockwise.

Assembly of Arbor

1. Machine spindle must be clean and free of debris.
2. Push the arbor firmly up into the internal spindle to lock into place.
3. To remove cutter arbor, insert drift key through key hole located on side of motor until arbor ejects.
4. To prepare for cutters, loosen set screws with hex keys (provided). INSERT PILOT INTO CUTTER HOLE AT SHANK END. Place shank of cutter into bottom of arbor. Align flats on shank with set screws and tighten until cutter locks into place.
5. To remove cutter, loosen set screws and pull.

Assembly of Drill Chuck for use with Straight Shank Tools

Drill chuck is optional: RB6512 (1/2" capacity) or RB6534 (3/4" capacity)

1. Place the drill chuck into the internal spindle, give a firm push to be sure it locks into place.
2. To remove, push drift key through drift key hole located on side of motor until drill chuck ejects.
3. To prepare drill chuck for drills, place chuck key into chuck key hole and turn counter clockwise. Place drill bit into drill chuck and turn chuck key clockwise until drill bit locks into place.
4. To remove drill bit, turn chuck key counter clockwise.

To use Taper Shank Drills and Reamers

1. Insert taper shank drill or reamer into internal #3MT spindle.
2. Make sure the tang on the taper shank drill or reamer is aligned correctly and locked into place.
3. To remove, insert drift key into slot located on side of motor and push through until drill or reamer is ejected.
4. If drill or reamer is not seated correctly, the tang will break off and may cause damage to internal spindle.

Assembly of Safety Guard

- Loosen screw from underneath the arbor support (front/center). Align the bracket slot with the screw, and tighten screw until safety guard locks into place.
- To remove safety guard, loosen screw and remove safety guard.

RB65E ELECTRICAL CONNECTION DIAGRAM

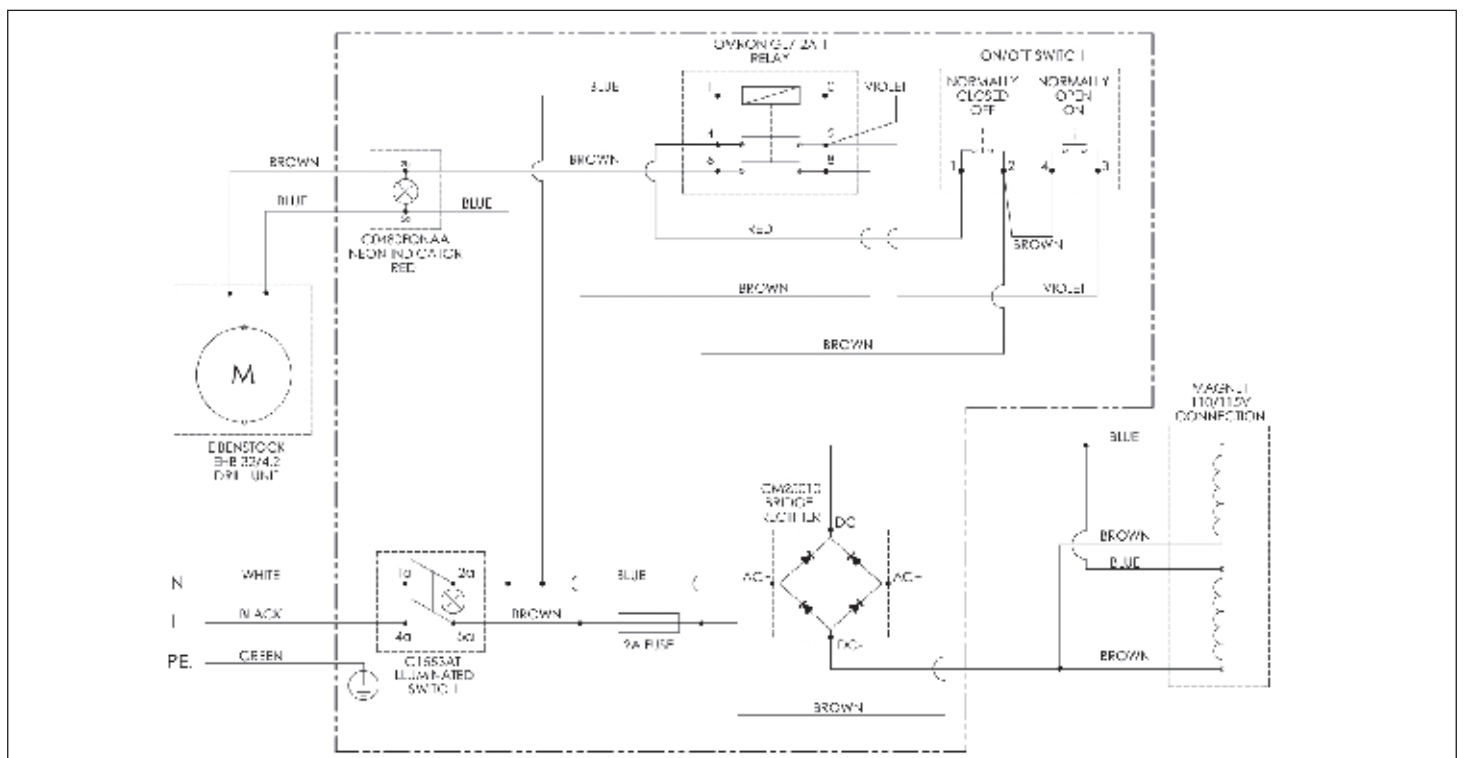



PORTABLE METAL DRILLING SYSTEMS

OTHER ROTOBRITE MACHINES AVAILABLE FROM CHAMPION



AC35 MiniBrute



AC50 MightiBrute



SB35 SmartBrute



RB30 LittleBrute



RB32 MiniBrute



RB32-VSR MiniBrute

Carbide Tipped Annular Cutter Ranges

CT150

1-3/8"
Depth of cut

CT200

2" Depth of cut

CT300

3" Depth of cut

CT400

4" Depth of cut



High Speed Annular Cutters

XL100

1" Depth of cut

XL200

2" Depth of cut

XL300

3" Depth of cut

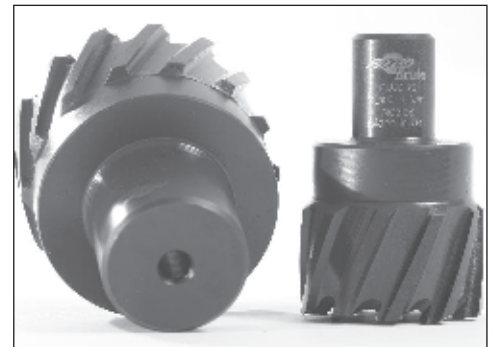

Carbide Tipped Stack Annular Cutters

CT150STK

Carbide Tipped
Stack Cut
1-3/8" Depth of cut

CT200STK

Carbide Tipped
Stack Cut
2" Depth of cut

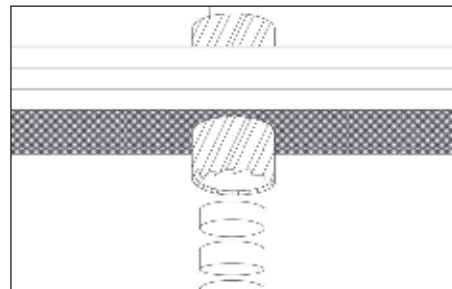
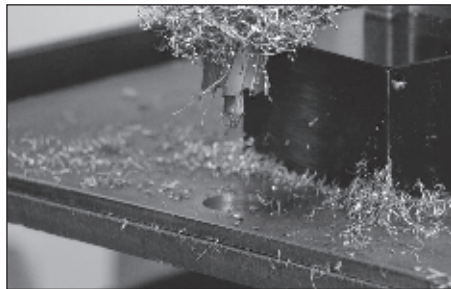

P.O.Box 368, Rockville Centre, NY 11571-0368

Tel: 516-536-8200 Fax: 516-536-8186

www.championcuttingtool.com